

SWINGTRIM CUTTERBAR KNIFE GUIDE ADJUSTMENT

Adjusting the Knife Guides

Before commencing any checks or adjustments lay the cutterbar flat on the ground, select cutterbar off', switch off the tractor remove starting key and disconnect the con rod.

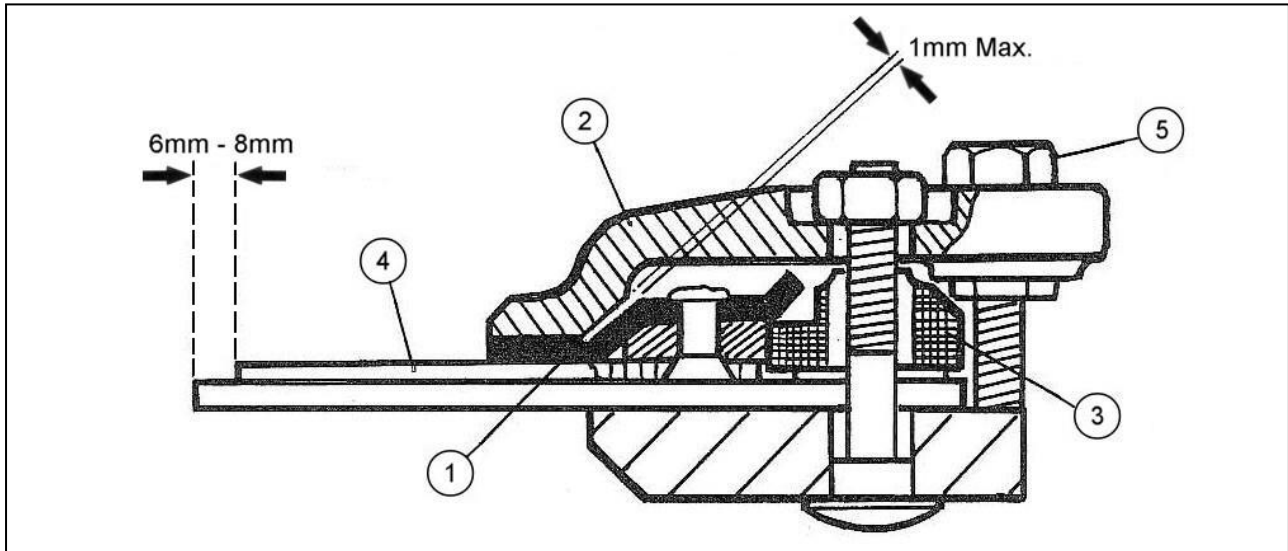

When adjusted correctly the knife sections (4) lie flush between the fingers and the underside of the knife holder (1) with the fingers projecting 6mm to 8mm in front of the knife tips. In addition there must be a maximum clearance of 1mm between the sloping faces of the knife holder (1) and the guide plate (2). This allows clearance for the knife to move freely and can be checked by placing a 5/8" dia bar into the con rod socket in the knife heel and operating by hand.

The guide plate (2) and rubbing plate (3) are mounted through slotted holes which allow the correct lateral positioning of the knife in relation to the fingers.

Any play caused by wear between the knife holder (1) and the knife sections (4) is removed by turning the setscrew (5). The knife guide should be adjusted until the mating faces are flush. No downward pressure should be exerted onto the knife as this may impede its free movement.

Sharpening the knife

After five to twenty operating hours, depending on the work involved, the knives require re-sharpening. It is recommended that the knives be removed from the cutterbar for re-sharpening. The procedure is as follows:

Switch off tractor and remove the starting key.

- Disconnect the con rod, remove the three setscrews securing the knife heel to the knife and withdraw the knife from the cutterbar.
- Clean the knife and ensure that neither the back nor the knife sections are bent – if required, straighten as necessary.

A cutting angle of 35° - 40° is required.

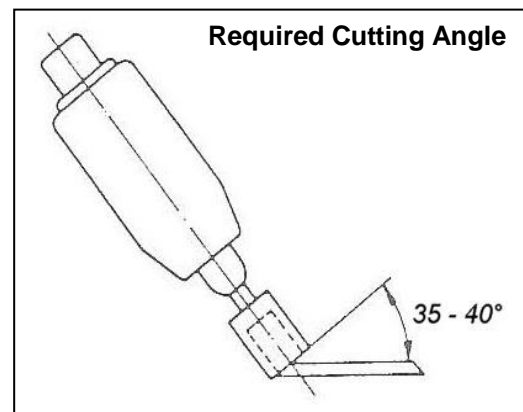

A high speed hand grinder should be used, with ideally, a pot shaped pencil grinder of approximately 1" (25mm) diameter by 1 3/8" (35mm) long. Grinding is carried out with the end face of the grinder moving from the base of the knife section up to the points.

It is possible to re-sharpen the knives in situ, the procedure is as follows:

Position the cutterbar on or parallel to the ground. Switch off the tractor engine and disconnect the con-rod. Manually position the knives so that they cover the fingers and clamp together in this position.

Sharpening with files is not recommended as the process tends to leave small burrs on the edge which curl under when the knife is replaced thus impeding the free movement of the knife and leaving a blunt cutting edge.

DANGER: It is imperative that great care is adopted at all times when working with the cutterbar to avoid injury – the use of safety gloves and safety glasses is recommended at all times when working with this and all associated components.

Hydraulic Pump Connections for Correct Crankshaft Direction

