

ROTARY DITCH CLEANER

The current Rotary Ditch Cleaner incorporates 120° hydraulic swivel to alter the direction of cut from, ditch cleaning to grip cleaning, and an hydraulically angled chute. A diverter valve is fitted to the ditcher to operate these services. Power can be taken from the tractor spool valve, from a diverter valve fitted to the hedge trimmer or on some models from a separate service.

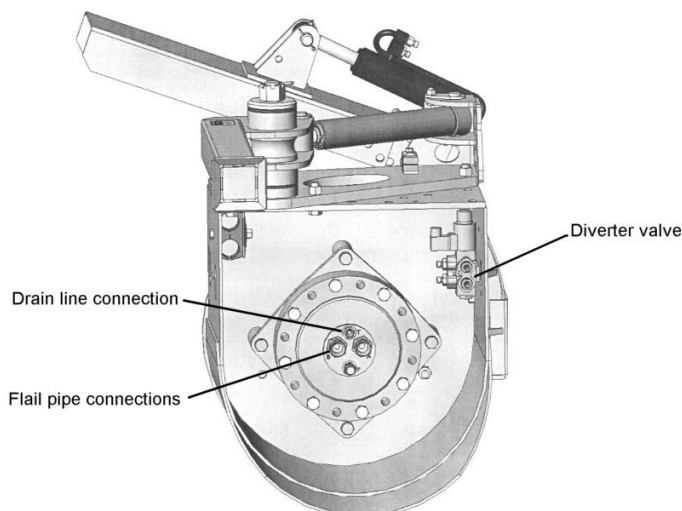

The flail hoses are connected to the two 1" unions and the drain line to the top connection as shown above. The drain line must go directly back to tank without any restriction, otherwise the motor shaft seals will fail. Connection to the tank is made by removing a blanking plug halfway down the side of the tank. On machines without this plug an alternative filler plate, incorporating a return connection, will be supplied.

Oil flow required is 100 l/m +

Serious damage can be caused to the motor if it is allowed to cavitate when being shut down. To prevent this a positive pressure must be maintained in the return line at all times. All machines with piston pumps or gear pump machines with electric rotor control valves will maintain sufficient back pressure. Machines fitted with Cable rotor control valves will not maintain sufficient pressure so a back pressure kit must be fitted when the ditcher is in use and removed when the flail head is fitted.

